



SANDHYA ENTERPRISES

AN ISO 9001:2015 Certified Company

Address: 5-24-1223/8/1, Ambedkar Nagar, Gajularamaram, Hyderabad – 500055.

AN ISO 9001:2015 Certified Company

Contact No: 9652998932

GSTIN: 36GNLPS1299P1ZS

Email : sandhyapprises@gmail.com

Website: www.sandhyaflex.com

WhatsApp: 9652998932

YouTube: www.youtube.com/c/SANDHYAENTERPRISES

Website : <http://www.sandhyaflex.com/pvc-water-...>

Request a Quote : <https://www.sandhyaflex.com/contactus-1.php>

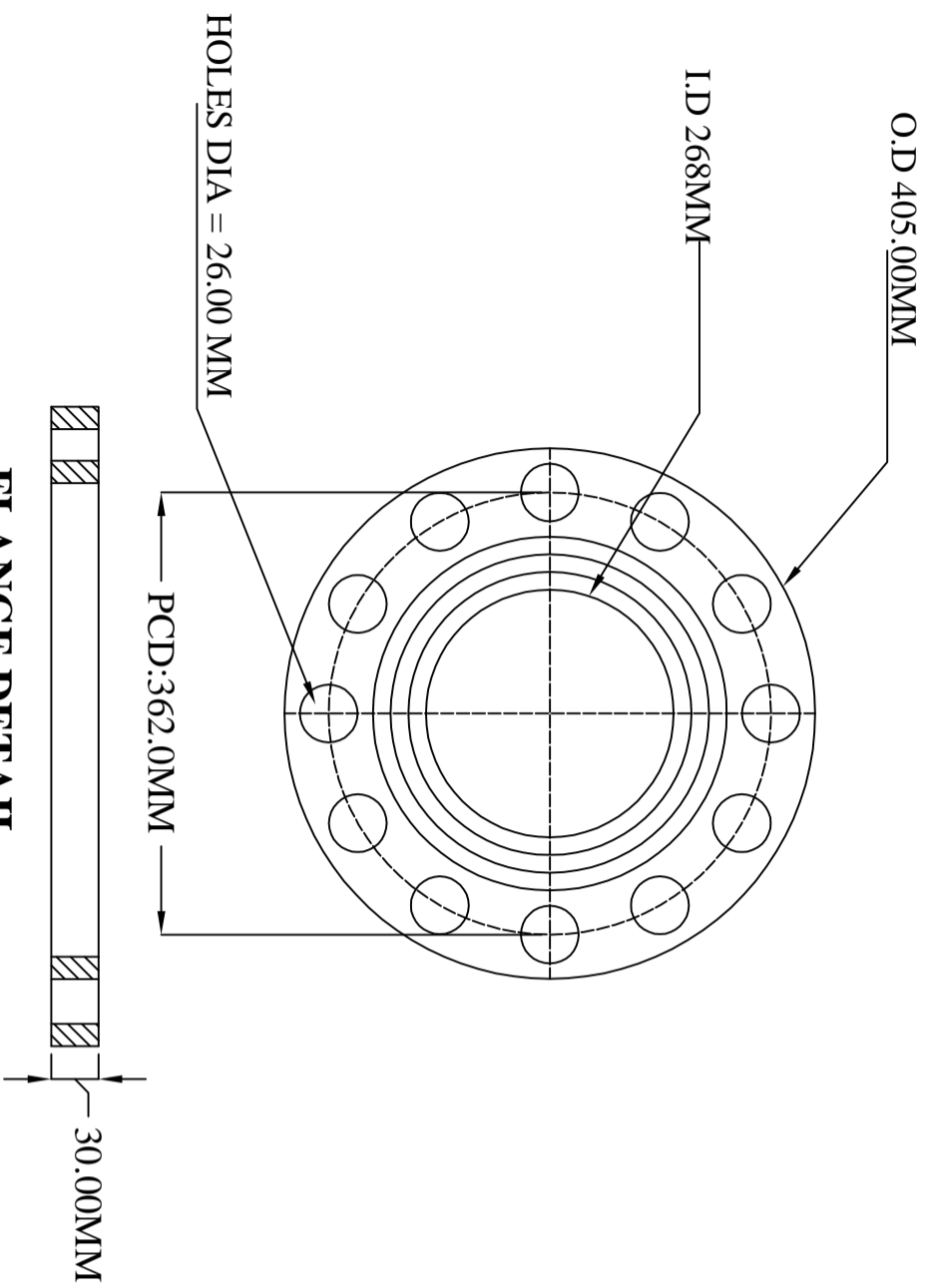
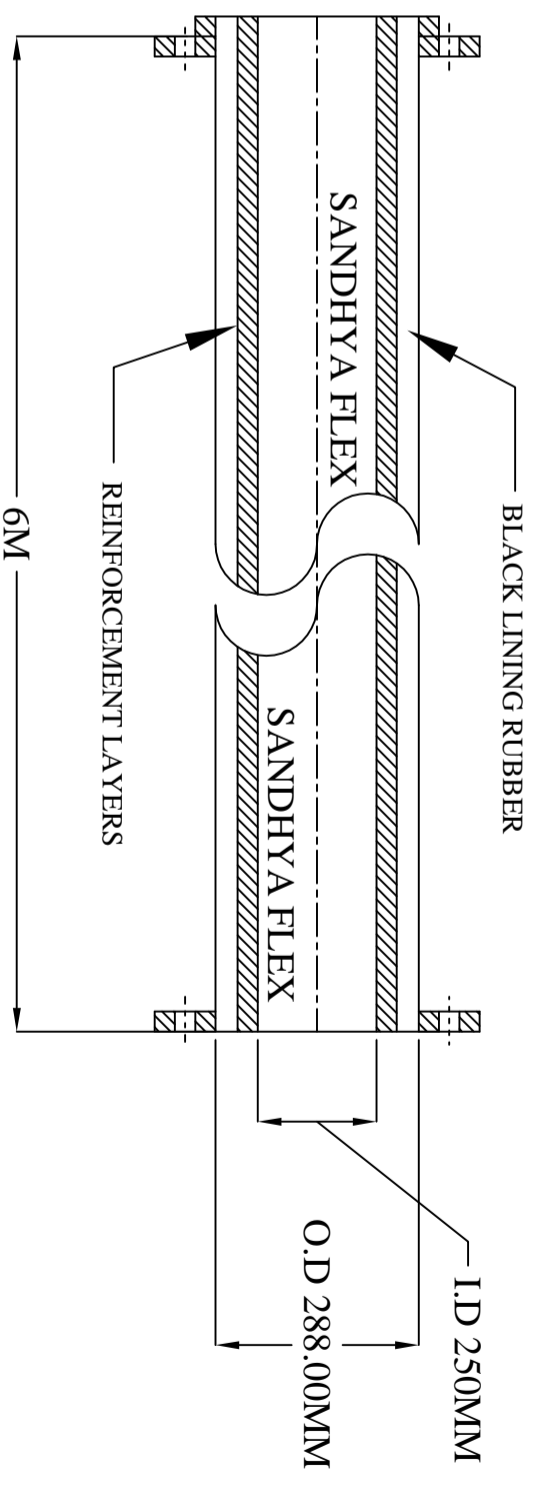

FLANGE DETAIL

FLANGE DIMENSION OF CLASS 150 FLANGE AS PER ANSI B 16.5

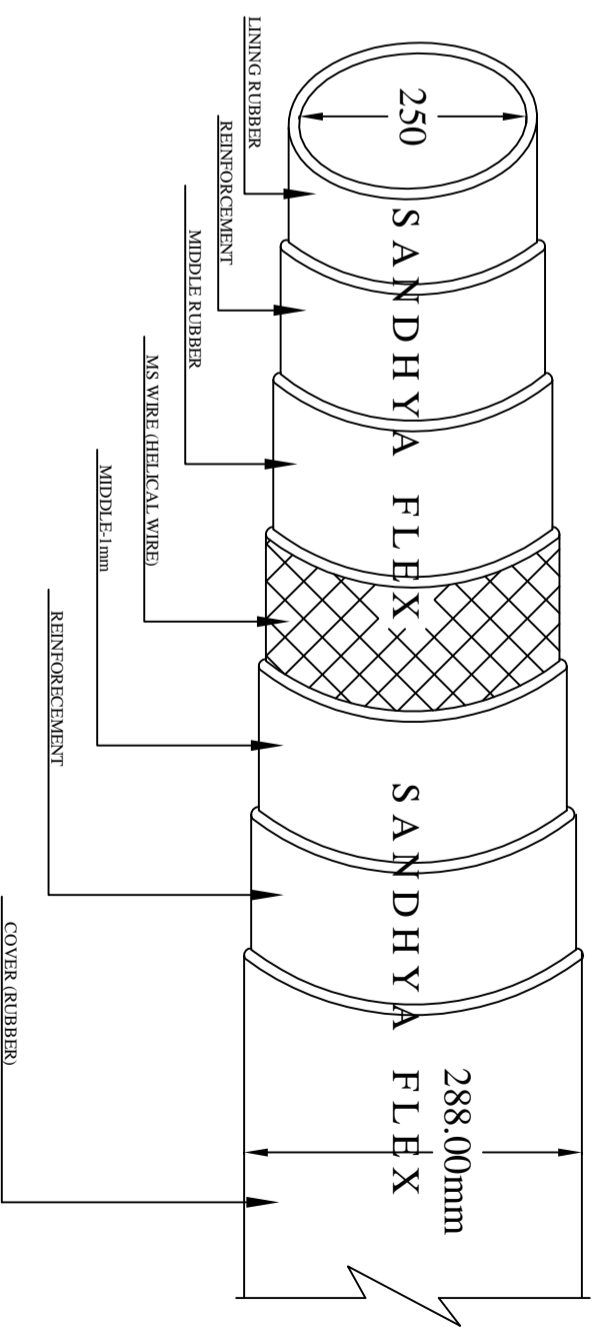

MOC OF RUBBER HOSE

TITLE:

SLURRY RUBBER HOSE WITH BOTH END FIXED M.S.FLANGE
PRESSURE: 25 KG/CM²
MAKE: SANDHYA FLEX

DRAWING NO:

SE/250ID/2020-2021

DRAWN BY: MD RAHMATH ALI
(B.TECH, CIVIL ENGG)

CHECKED BY:
MITHILESH CHAUDHARY



SANDHYA ENTERPRISES
HYDERABAD